



flowpack machinery by
FOODPACK S.R.L.



Versione integrale ad assi interpolati

Plani di scorrimento e carter in acciaio Inox AISI 304
da 5 a 7 motori indipendenti:

- Motore BRUSHLESS per nastro di alimentazione
- Motore BRUSHLESS per gruppo di saldatura longitudinale
- Motore BRUSHLESS per gruppo di saldatura trasversale
- 2 Motori asincroni con inverter + 2 motori in CC (vers. Gold)

Realizzazione integrale secondo le norme "CE"



Full version with axis motion controller

Flat surfaces, coverings and bottom belt in STAINLESS STEEL
from 5 to 7 independent motors:

- BRUSHLESS motor for infeed conveyor
- BRUSHLESS motor for longitudinal sealing unit
- BRUSHLESS motor for box motion sealing unit
- 2 asynchronous motors + inverters and 2 DC motors (Gold vers.)

Machine's manufacture complies "CE" REGULATIONS



Komplett Servo gesteuert Antriebe

Abdeckungen und Schutzverkleidungen in Edelstahl

Von 5 bis 7 Unabh angig gesteuerte Motoren:

- Antrieb der Fingerzufuehrung  ber Servomotor
- Antrieb der Laengsschweissung  ber Servomotor
- Antrieb der Querschweissung  ber Servomotor
- 2 frequenzgest. Motoren und 2 Gleichstrom-Motoren (Gold Aus.)

CE-konform



Version int egrale avec axes interpol es

Plans d' coulement et carter en acier Inox AISI 304
de 5   7 moteurs ind ependants:

- Moteur BRUSHLESS pour tapis d'alimentation
- Moteur BRUSHLESS pour groupe de soudure longitudinale
- Moteur BRUSHLESS pour groupe de soudure transversale
- 2 Moteurs asynchrones et 2 moteurs en CC (vers. Gold)

R ealisation Int egrale sur la base des r egles "CE"

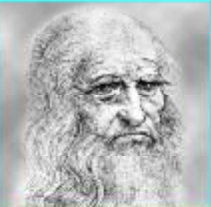

LEONARDO 700-900-1.000

PBB DIGIT HS



...the art of packaging

LEONARDO 700 – 900 – 1000 PBB DIGIT HS



				700	900	1000
Larghezza film	Film width	Follienrollenbreite	Largeur de bobine	700mm	900mm	1000mm
Larghezza Taglia cuci	Sealing unit width	Siegelbackenbreite	Largeur machoires	350mm	400mm	500mm
Altezza max prod.	Max product height	Producthöhe max	Hauteur produit	200mm *		
Lunghezza max prod.	Max product length	Productlänge max	longueur max Produit	∞ mm *		
Larghezza max prod.	Max product width	Productbreite max	Largeur max produit	300mm*	350mm*	450mm *
Voltaggio	Power connection	Elektroanschluß	Tension	380V 50Hz 3ph + N + E		
Potenza installata	Max Connected load	Anschlußwert	Puissance	6 - 7 KW		
Pressione aria	Air pressure	Pneumaticscluß	Pression de l'air	6 bar		

* these dimensions cannot be considered simultaneously . see drawing below.

Disponibile anche in **VERSIONE GOLD**: Pannello operatore con TOUCH SCREEN 10,4" a colori, Regolazione altezza gruppo di saldatura longitudinale tramite motore CC, Regolazione altezza Taglia-cuci tramite motore CC, Pneumatica FESTO.

GOLD VERSION available, complete with: Colour touch screen 10.4", longitudinal and transversal sealing unit height adjustable through DC motor, FESTO pneumatics.

GOLD AUSFÜHRUNG mit: Bedienfeld Touch-screen 10.4", Höhe der Siegelrollen und der Querschweißung motorisch einstellbar über Touch-screen, Pneumatikkomponenten FESTO.

Disponibile en **VERSIONE GOLD**, avec: écran tactile 10.4", réglage de la hauteur de l'unité de soudure transversale et longitudinale avec écran tactile, pneumatique FESTO.

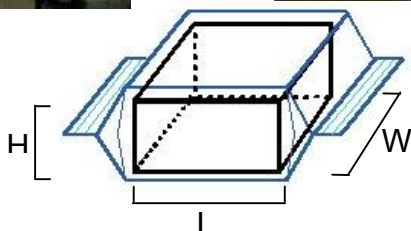

$$(W+H+25)*2 < 700$$

$$(W+H+25)*2 < 900$$

$$(W+H+25)*2 < 1000$$

$$W < 300$$

$$W < 350$$

$$W < 450$$

$$H < 200\text{mm}$$

$$L < \infty \text{ mm}$$

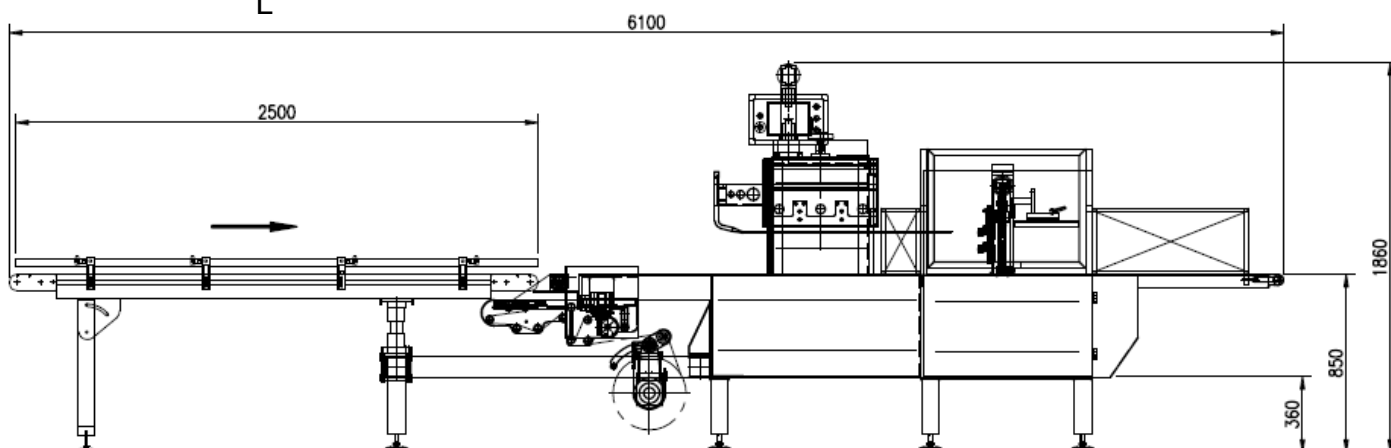

I dati contenuti non sono vincolanti e possono essere modificati senza preavviso. Data here contained are not binding and subjected to modifications with no prior notice

www.foodpack.it



FOOD

NON-FOOD

BIO MEDICAL

COSMETICS

FOODPACK SRL

Via lago di Pusiano 28
36015 Schio (VI) – ITALY
Tel. +39 (0)445 069 000
Fax. +39 (0)445 069 001