



flowpack machinery by
FOODPACK S.R.L.



Versione integrale ad assi interpolati

Piani di scorrimento e carter in acciaio Inox AISI 304

4 motori indipendenti:

- Motore BRUSHLESS per nastro di alimentazione
- Motore BRUSHLESS per gruppo di saldatura longitudinale
- Motore BRUSHLESS per gruppo di saldatura trasversale
- Motore asincrono con inverter per nastro di uscita

Realizzazione integrale secondo le norme "CE"



Full version with axis motion controller

Flat surfaces, coverings and bottom belt in STAINLESS STEEL

No. 4 independent motors:

- BRUSHLESS motor for infeed conveyor
- BRUSHLESS motor for longitudinal sealing unit
- BRUSHLESS motor for transversal sealing unit
- asynchronous motor + inverter for outfeed conveyor belt

Machine's manufacture complies "CE" REGULATIONS



Komplett Servo gesteuert Antriebe

Abdeckungen und Schutzverkleidungen in Edelstahl

Nr 4 Unabh angig gesteuerte Motoren:

- Antrieb der Fingerzuf uhrung  ber Servomotor
- Antrieb der L ngsschweissung  ber Servomotor
- Antrieb der Querschweissung  ber Servomotor
- Auslaufband frequenzgesteuert

CE-konform



Version int grale avec axes interpol s

Plans d' coulement et carter en acier Inox AISI 304

4 moteurs ind pendants:

- Moteur BRUSHLESS pour tapis d'alimentation
- Moteur BRUSHLESS pour groupe de soudure longitudinale
- Moteur BRUSHLESS pour groupe de soudure transversale
- Moeur asynchrone avec inverter pour tapis de sortie

R alisation int grale sur la base des r gles "CE"



PALLADIO

FAST 500 DIGIT



...the art of packaging



PALLADIO FAST 500 DIGIT



Larghezza film	Film width	Folienrollenbreite	Largeur de bobine	Max 500mm
Larghezza Taglia cuci	Sealing unit width	Siegelbackenbreite	Largeur machoires	260mm
Altezza max prod.	Max product height	Producthöhe max	Hauteur produit	100mm *
Lunghezza max prod.	Max product length	Productlänge max	longueur max Produit	500mm *
Larghezza max prod.	Max product width	Productbreite max	Largeur max produit	200mm *
Voltaggio	Power connection	Elektroanschluß	Tension	380V 50Hz 3ph + N + E
Potenza installata	Max Connected load	Anschlußwert	Puissance	3 - 4 KW
Pressione aria	Air pressure	Pneumaticsanschluß	Pression de l'air	6 bar

* these dimensions cannot be considered simultaneously . see drawing below.

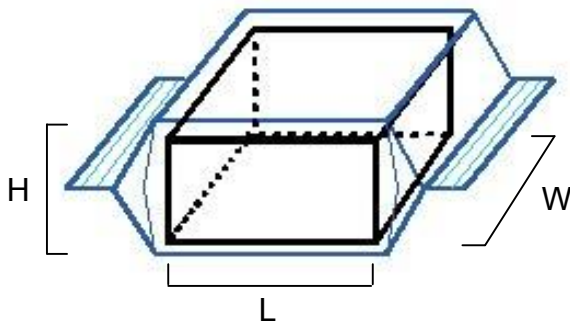

$$(W+H+25)*2 < 500\text{mm}$$

$$H < 100\text{mm}$$

$$W < 200\text{mm}$$

$$L < 500\text{mm}$$

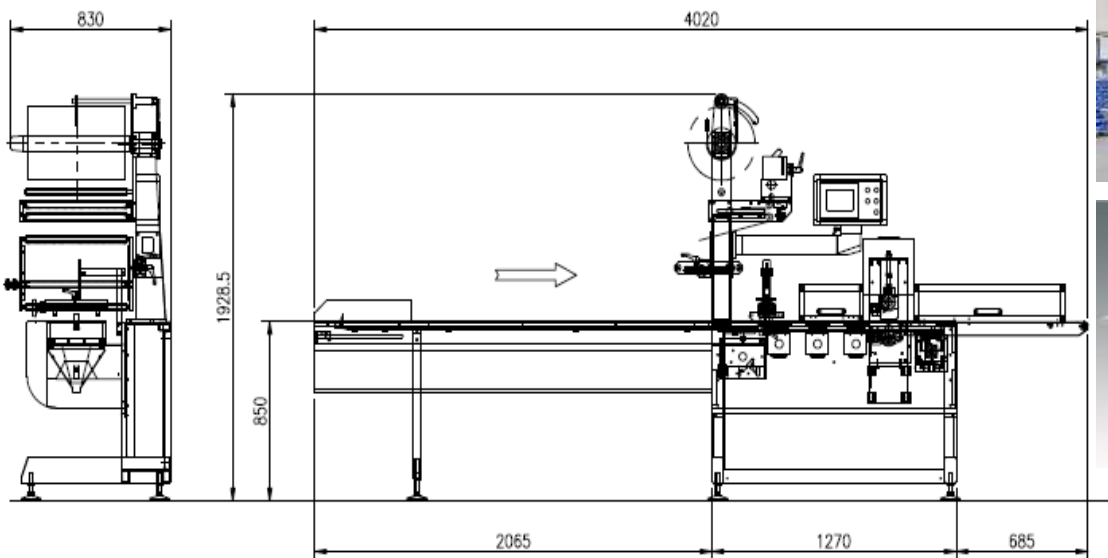

info@foodpack.it

www.foodpack.it

FOODPACK SRL

Via lago di Pusiano 28
36015 Schio (VI) – ITALY

Tel. +39 (0)445 069 000

Fax. +39 (0)445 069 001



FOOD

NON FOOD

BIO MEDICAL

COSMETICS