



flowpack machinery by
FOODPACK S.R.L.



Versione integrale ad assi motorizzati

Struttura cantilever facilmente sanificabile con finiture Inox AISI 304

3 motori indipendenti:

- Motore per nastro di alimentazione
- Motore per gruppo di saldatura longitudinale
- Motore per tappeto d'uscita
- Predisposta per lavaggio gas (MAP)
- Disponibile anche con nastro a palette con punto di caduta registrabile

Realizzazione integrale secondo le norme "CE"



Version with axis motion controller

Flat surfaces, coverings and bottom belt in STAINLESS STEEL

3 independent motors:

- Infeed conveyor
- Longitudinal sealing unit
- Outfeed conveyor belt

Suitable for Modified Atmosphere Packaging (Gas flushing)

Special infeed conveyor for long/short products AVAILABLE

Machine's manufacture complies "CE" REGULATIONS



Servo gesteuert Antriebe

Abdeckungen und Schutzverkleidungen in Edelstahl

Nr 3 Unabhængig gesteuerte Motoren:

- Antrieb der Fingerzuführung
- Antrieb der Laengsschweissung
- Antrieb der Auslaufband

Vorraetig mit einstellbar Fingerzufuehrung fur lange/kurze Produkte

Vorraetig mit Begasungseinrichtung

CE-konform



Version avec moteurs indépendants

Plans d'écoulement et carter en acier Inox AISI 304

3 moteurs indépendants:

- Moteur pour tapis d'alimentation
- Moteur pour groupe de soudure longitudinale
- Moteur pour le tapis de sortie

Disponible avec tapis dalimentation réglable pour produits longs et courts

Disponible pour le conditionnement sous atmosphère modifiée

Réalisation intégrale sur la base des règles "CE"



RAFFAELLO 500 & GAS
RAFFAELLO 500 & GAS FLEX



...the art of packaging



RAFFAELLO 500 & GAS



Larghezza film	Film width	Follienrollenbreite	Largueur de bobine	Max 500mm
Larghezza Taglia cucì	Sealing unit width	Siegelbackenbreite	Largueur machoires	260mm
Altezza max prod.	Max product height	Producthöhe max	Hauteur produit	100mm *
Lunghezza max prod.	Max product length	Productlänge max	longueur max Produit	999mm *
Larghezza max prod.	Max product width	Productbreite max	Largueur max produit	200mm *
Voltaggio	Power connection	Elektroanschluß	Tension	380V 50Hz 3ph + N + E
Potenza installata	Max Connected load	Anschlußwert	Puissance	3 - 4 KW
Pressione aria	Air pressure	Pneumaticsanschluß	Pression de l'air	6 bar

* these dimensions cannot be considered simultaneously . see drawing below.

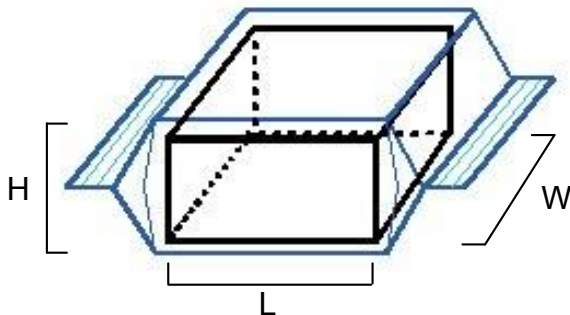

$$(W+H+25)*2 < 500\text{mm}$$

$$H < 100\text{mm}$$

$$W < 200\text{mm}$$

$$L < 999\text{mm}$$

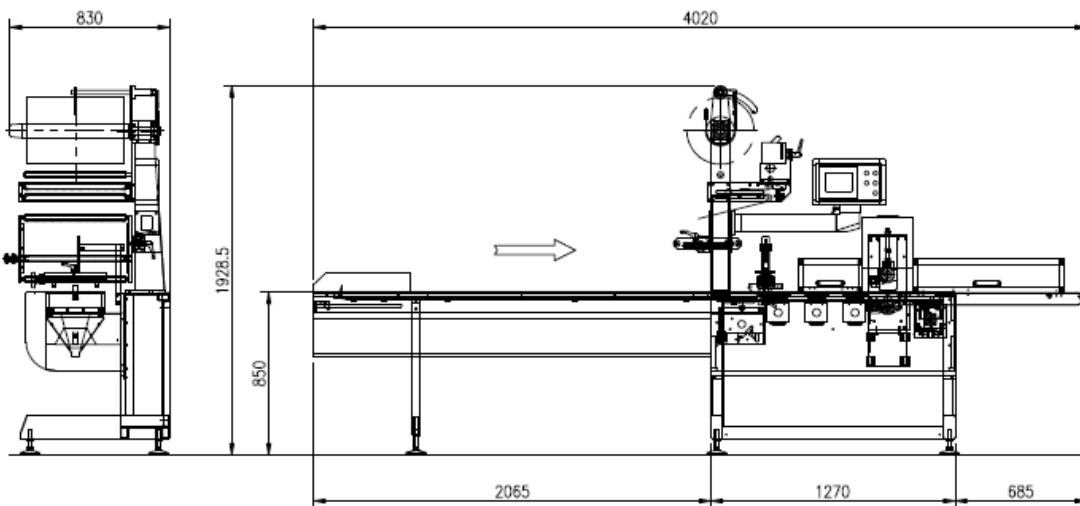

info@foodpack.it

www.foodpack.it

FOODPACK SRL
Via lago di Pusiano 28
36015 Schio (VI) – ITALY
Tel. +39 (0)445 069 000
Fax. +39 (0)445 069 001



FOOD

NON FOOD

BIO MEDICAL

COSMETICS